

Formation of super disperse phase and its influence on equilibrium and thermodynamics of thermal dehydration

O.G. Polyachenok^{a,*}, E.N. Dudkina^a, N.V. Branovitskaya^a, L.D. Polyachenok^b

^a Department of Chemistry, Mogilev State University of Foodstuffs, 212027, Belarus

^b Department of Chemistry, Mogilev State University of A.A. Kuleshov, 212022, Belarus

Received 22 July 2007; received in revised form 31 October 2007; accepted 11 November 2007

Available online 19 November 2007

Abstract

New data on the dehydration and rehydration processes of calcium, manganese and copper dichlorides are presented that reveal surprising, in a certain sense, behaviour difficult to be explained for the last two chlorides in terms of the usual conception of thermodynamic equilibrium. A substantial role of a super disperse phase at studying the equilibrium of the thermal decomposition of a hydrate is postulated to explain the experimental results for manganese and copper dichlorides. It is shown that the formation of such a phase of the hydrate is able to change appreciably the experimental results, causing the increase of water vapour pressure and the decrease of the derived enthalpy of a reaction. The results obtained allow to understand the reasons for considerable differences of some literature data. They enable to receive more precise and reliable data for thermal dehydration and probably for some other decomposition processes.

© 2007 Elsevier B.V. All rights reserved.

Keywords: Super disperse phase; Thermodynamics; Thermal dehydration; Water vapour pressure; TG; Metal chloride

1. Introduction

In a detailed and comprehensive analysis of numerous existing data on thermal dehydration of crystalline solids Galwey [1] introduced and developed new approaches for understanding the nature of this important group of heterogeneous reactions. Great attention was paid to the structural changes and mechanisms of interfacial processes and their influence on the thermal dehydration kinetics; but the problems of equilibrium and thermodynamics have not been practically touched.

Do these interfacial processes have any relation to equilibrium and the received thermodynamic properties of the reactants? At first sight they do not, as equilibrium is a stable state of a system, not depending on its history and the rate of equilibration. That is, the results of a thermodynamic study of thermal dehydration should not be influenced by any peculiarities of its mechanism – all the participating phases should have their equilibrium structure, and the system should be characterized by the minimum of the Gibbs energy.

Such an approach is theoretically absolutely correct, except for the two obvious and important circumstances. The first, the reality is that the experiment cannot continue infinitely long, and the second, the process of equilibration may proceed very slowly. Therefore, in practice we encounter very often a quasi-equilibrium state of a system, which is not always easy to distinguish from the true equilibrium. Thus, there is no simple and definite reply to the above-asked question.

In this paper, we present the experimental results on the dehydration and rehydration processes of calcium, manganese and copper dichloride hydrates. The data obtained for the last two chlorides permit us to suppose a substantial role of the interfacial processes in special cases of the thermodynamic investigations of thermal dehydration. The choice of these substances was not accidental – all of them have a rather high desiccating ability, anhydrous CaCl_2 is widely used in industry and laboratories; MnCl_2 is a promising desiccant, and CuCl_2 was recently shown [2,3] to be a desiccant with a very low temperature of regeneration:

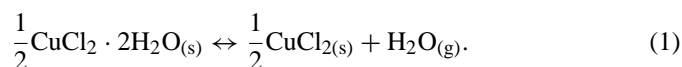

The latter chloride has an important peculiar property – it forms the only one hydrate stable at ordinary conditions, the

* Corresponding author.

E-mail address: polyachenok@mogilev.by (O.G. Polyachenok).

dihydrate. Therefore, in this case we may expect the easiest interpretation of the experimental results. Indeed, the most conclusive proof on the problem concerned was received for this chloride in particular.

2. Experimental

2.1. Chemicals

All used chemicals were of analytical or chemical grade purity. Anhydrous CaCl_2 and MnCl_2 were obtained by careful and stepped heating of the recrystallized hydrates in the oven up to the temperature 520 K. Special attention was paid to prepare pure $\text{CuCl}_2 \cdot 2\text{H}_2\text{O}$, since there are many differences in literature concerning its characteristics. This hydrate was prepared by double recrystallization of a commercial sample from hot water, slightly acidified with HCl. The crystals were washed with cold water on a glass filter and dried in air; they form small blue needle-like crystals. They are noticeably hygroscopic, probably due to the adsorption of water vapour on the surface of the crystals. Anhydrous CuCl_2 was obtained by heating the hydrate in the oven at the temperature 390 K. All the concerned anhydrous salts are strongly hygroscopic.

2.2. Experimental procedure

In order to reveal the desired information, the experimental methods should be used allowing to receive not only the equilibrium knowledge but also some features of the dynamics of the concerned process. Therefore, two methods of this kind were chosen to measure the equilibrium water vapour pressure for the systems, including the anhydrous salts and their lowest hydrates.

The first one was the gas transpiration technique. A schematic diagram of the arrangement used is shown in Fig. 1. The flow of nitrogen was passed through a filter bed of the chloride and its hydrate (Fig. 2), and the partial water pressure at the outlet of the apparatus was found gravimetrically.

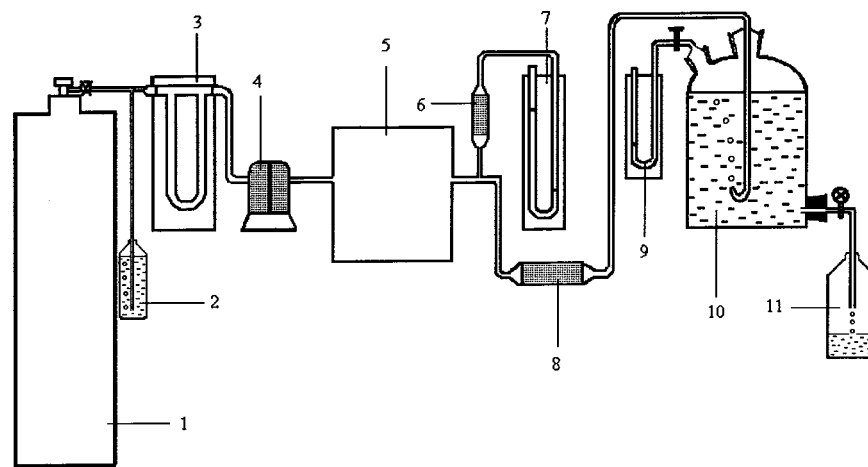

Fig. 1. Schematic diagram of the arrangement for the gas transpiration technique: 1, nitrogen cylinder; 2, manostat; 3, capillary rheometer; 4, CaCl_2 or water saturator in a Dewar; 5, saturation block; 6, CaCl_2 protection; 7, large water manometer; 8, weighed absorption vessel; 9, small water manometer; 10, large bottle to collect nitrogen; 11, bottle to collect water.

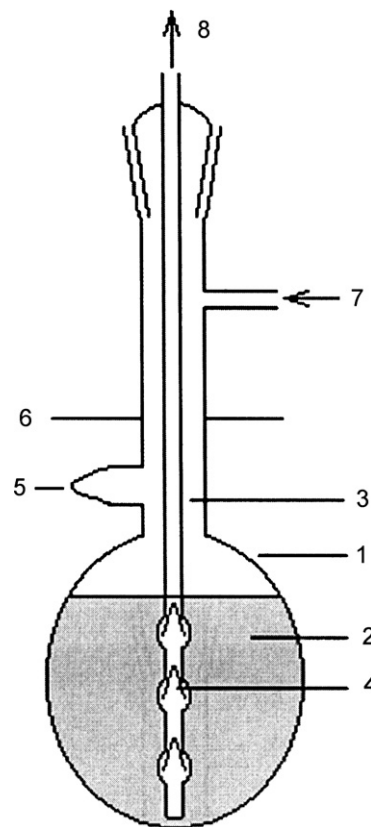

Fig. 2. Reaction vessel for the gas transpiration technique: 1, pyrex glass flask; 2, substance; 3, inner glass tube to withdraw gas; 4, glass fiber filter; 5, sealed off tube for loading substance; 6, water level in thermostat; 7, gas supply; 8, gas outlet.

A special procedure was used to prepare granulated chlorides applied on the surface of silica gel. Silica gel was ignited in the oven for 10 h at 1270 K to produce 1–2 mm granules with closed porosity. It was denoted by the considerable growth of bulk density, from 0.41 g cm^{-3} for the initial silica gel reduced to the similar particle size, to 1.28 g cm^{-3} for the ignited product. The specific water vapour sorption was determined gravimetrically

for both forms of silica gel in the same conditions (indoor air, 294.5–295.3 K, water vapour pressure 15.2–16.1 hPa); it was equal to 55.2 mg g⁻¹ for the initial silica gel (for the sample 8.1719 g) and 0.044 mg g⁻¹ for the ignited sample (13.4890 g). It is important to note that this small limiting value of water sorption was reached relatively quickly, in 1.5 h, whereas for the initial porous sample it lasted for more than 70 h. The main conclusion that follows from the above data is that silica gel particles had too little surface area to produce any noticeable influence on the results of the transpiration experiments. In addition it is worth to mention that, for instance, the total receptivity of copper chloride in the reaction flask (76 g) to water vapour was about 20 g, while for the ignited silica gel particles (100 g) – only 4.4 mg.

The procedure of making the chloride granules may be illustrated by the example of copper (II) chloride. Hundred grams of both the ignited silica gel and the ground CuCl₂·2H₂O were mixed in a porcelain evaporating dish together with 20 ml of water, and thoroughly stirred with a glass rod to give a dense pulp. The latter was heated on the hot plate at continuous stirring until all the solution was evaporated, and then dried at 395 K. The received granules (197 ml and 176 g) were 2–3 mm in diameter, and contained the average 43 mass% of anhydrous copper (II) chloride. These granules were put into the reaction flask (Fig. 2) through the side tube 5 in such a way that all the small particles of CuCl₂, torn off the granules and stuck to the glass, should be placed below the water level in the thermostat. For the same reason, glass fiber filters were used (4) to prevent these particles of CuCl₂ from being carried out to the cold zone by the gas flow.

The flow of nitrogen was either dried with calcined CaCl₂ (4) (Fig. 1) or instead, saturated with water vapour at the appropriate temperature. In the first case, the partial water pressure in nitrogen was lower than the decomposition pressure of the hydrate. Therefore reaction (1) proceeded from left to right, and we could achieve the equilibrium state “from below”. In the second case, on the contrary, reaction (1) proceeded from right to left, and we could reach the equilibrium state “from above”. Temperature of the water saturator was chosen in this case from the condition, that the saturation water pressure should be somewhat higher, than the decomposition one. For instance, at studying the system CaCl₂–CaCl₂·H₂O, the water saturator was placed into a Dewar flask with melting ice. Delivery of moist and dry gas was alternated, and reproducible results were achieved.

At the same time, the above-mentioned saturation water pressure was always somewhat lower than the saturation water pressure at room temperature to avoid condensation in the connections. The latter were made of pvc-tubes and tested not to pass any perceptible amount of water vapour.

The saturation block (5) (Fig. 1) consisted of a water thermostat with a mercury-contact regulating thermometer, capable to keep temperature constant to 0.01 K, and the reaction vessel (Fig. 2). Water temperature was measured to 0.01 K with a calibrated mercury thermometer using a magnifying glass. The overall uncertainty of the temperature measurements, taking into consideration all the necessary corrections, was ±0.05 K.

The mass of water vapour evolved was determined by weighing (±0.1 mg) the absorption vessel (8) filled with Mg(ClO₄)₂

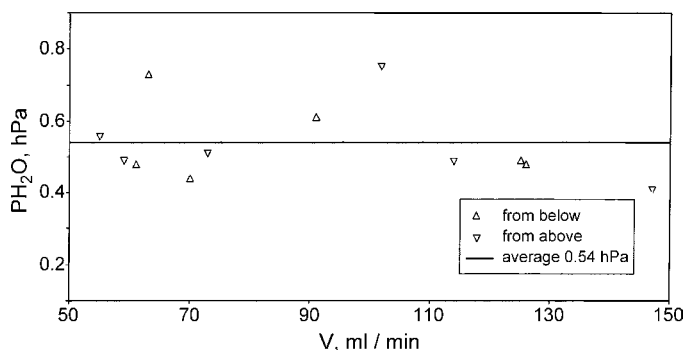

Fig. 3. Water vapour pressure for the system CaCl₂–CaCl₂·H₂O at 334.05 K.

or CaCl₂, depending on the value of the vapour pressure. The volume of the flowing gas and the time of the experiment were chosen such that the increase of the mass of the absorption vessel (8) was never less than 10 mg, to ensure sufficient measurement accuracy.

The flow rate of the gas has been chosen for each substance and for each temperature to achieve equilibrium. As is seen in Figs. 3 and 6, horizontal lines are observed for CaCl₂ in a rather wide range, from 55 to 145 and from 40 to 170 ml min⁻¹, and this is usually interpreted as indicating the equilibrium attainment. More convincing is the argument based on coincidence of the results obtained “from below” and “from above”, and these are the results received for CaCl₂ at 334.05 K (Fig. 3).

It is worth to note that the contact time in these experiments varied from 1.2 to 5 min, and the total duration of an experiment was usually 30–170 min, depending on the value of water vapour pressure, rate and volume of the gas passed. The latter was usually 1.4–7 l, but in special cases, when the water vapour pressure was very low, it increased to 99–117 l and then the experiment lasted for 10–11 h (for CaCl₂ at standard temperature).

The volume of the flow gas was found gravimetrically with accuracy to ±0.1%. As it is seen in Fig. 1, the aspirator (Marriott’s bottle) was used to collect the gas at the outlet of the apparatus. It allowed to maintain a constant gas flow and included two bottles – large ten-litre bottle (10) for the gas and one-litre bottle (11) for the dripping out water. The latter was periodically weighed to 1 g and the found mass was converted to the gas volume *V* using the water’s density. Water in bottle (10) was saturated with nitrogen for 0.5 h at the preliminary work of the apparatus without the absorption vessel (8) to achieve the steady-state conditions.

Calculations of the water vapour pressure *P_w* from the experimental results were made using the equation

$$P_w = (P_b + \Delta_1 P)N, \quad (2)$$

where (*P_b* + $\Delta_1 P$) is the total pressure of the gas not far from the saturation block (Fig. 1), *P_b* – the atmospheric pressure, measured with a mercury barometer to 0.1 hPa, $\Delta_1 P$ – reading of the manometer (7) (Fig. 1) and *N* is the molar fraction of water vapour in the mixture with nitrogen. It was calculated from the mass increase of the absorption vessel (8) due to the sorption of water vapour, and the received amount of nitrogen. The latter was calculated according to the ideal gas law from *V*, temperature *T*

of water in bottle (10), pressure $P = P_b - P_{\text{sat}} + \Delta_2 P$, where P_{sat} is the saturation vapour pressure of water at the temperature T , $\Delta_2 P$ – reading of the manometer (9).

Use of eq. (2) may be illustrated with a typical example for the copper chloride dihydrate at 328.30 K. The measured quantities were: the atmospheric pressure $P_b = 970.3$ hPa; volume of the gas $V = 1853$ ml; water temperature $T = 293.6$ K ($P_{\text{sat}} = 24.0$ hPa); $\Delta_1 P = 20.9$ hPa; $\Delta_2 P = 3.5$ hPa; increase in mass of the vessel (8) 25.4 mg. The resulting value of the water vapour pressure P_w was calculated to be 19.0 hPa.

Precision of the results and certainty, that all the methodical factors had been taken into proper consideration, were verified by measuring the equilibrium values of the saturated vapour pressure for the standard substance – pure water. In this case a special device was constructed, instead of shown in Fig. 2, to receive the perfect saturation of the flowing gas, as is illustrated in Fig. 4.

Glass beads in Fig. 4 played two roles: the first, they slowed down lifting of the gas bubbles to ensure more complete saturation, and the second, they inhibited water spattering at its surface. The absorption vessel (4) was filled with $\text{Mg}(\text{ClO}_4)_2$ or CaCl_2 , and its upper part was positioned above the thermostat water to ensure the best absorption of water vapour. The protective skirt (5) was made of filter paper and prevented the trickling down water from getting into the inlet of the vessel (4).

At the end of the experiment, the upper rubber stopper (Fig. 4) was withdrawn together with the vessel (4) and both openings

were immediately closed with short pvc-tubes with glass beads. The vessel was cooled in a desiccator and slightly opened before weighing to equalize pressure.

The experiments showed that in our conditions the rate of saturation in the case of water was lower, than for the chloride systems studied, it is well seen in the diagrams of the received pressure versus gas flow rate, since the plateau was usually narrower. It visibly shortened at temperature rise, and this was the main reason for the upper limit of such measurements. Special experiments have been made to replace nitrogen with helium. Indeed, the rate of saturation increased noticeably, but new problems arose due to the rapid diffusion of helium through the pvc-tubes – it was difficult to obtain a precise mass of the absorption vessel. Therefore, all the measurements for the chloride systems were carried out with the nitrogen gas flow.

The following values of the water saturated vapour pressure were received as a result (obtained/standard values, hPa) at the temperatures 273.15 K ($6.17 \pm 0.21/6.11$), 290.13 K ($19.53 \pm 0.16/19.35$), 301.98 K ($39.65 \pm 0.44/39.65$) and 313.31 K ($74.4 \pm 1.3/74.38$), where the confidence interval (0.95) is given. These results permit us to conclude that the realized variant of the gas transpiration technique enables to receive sufficiently accurate and reliable data. Thus, we may hope that all the necessary precautions have been undertaken to ensure the exact values of the dehydration water vapour pressure obtained using this method.

The other method was the weight modification of the static method, using the thermobalance of the Paulik–Paulik–Erdey Q-derivatograph (TG). Its sensitivity allowed observing a change in mass of a sample down to ± 0.1 mg. The gas flow of dry argon or argon saturated at fixed temperature with water vapour passed over the substance at the rate of $15\text{--}20$ ml min^{-1} . If this water pressure was equal to the pressure of thermal dissociation of the hydrate, the indication of the balance was constant. Otherwise it showed the increase or loss of the substance mass that was determined visually on the scale of the balance. Measurements were made at the constant water vapour pressure, and the temperature was varied, until both became constant – the mass and the temperature. Thus, we could observe the equilibrium state at the fixed temperature and water vapour pressure, or, more precisely, the quasi-equilibrium, for it lasted no longer than 10–15 min.

Pure argon was dried with anhydrous $\text{Mg}(\text{ClO}_4)_2$. Otherwise it was saturated with water vapour by passing through a special vessel, containing distilled water and placed into the Dewar flask, also filled with water. The temperature of this water was measured with a mercury thermometer to 0.1 K and was chosen according to the two conditions. The first, it should be as high as possible since the sensitivity of this method increase with the water vapour pressure. The second, it should be somewhat lower than the room temperature to avoid the vapour condensation in the connections. Thus, it was chosen in a narrow interval of 286–290 K, providing the water vapour pressure in the range of 15–20 hPa. The overall uncertainty of the water vapour pressure measurements in these experiments was estimated to be ± 0.5 hPa. The degree of saturation was sometimes checked by weighing the absorption vessel, placed instead of the device

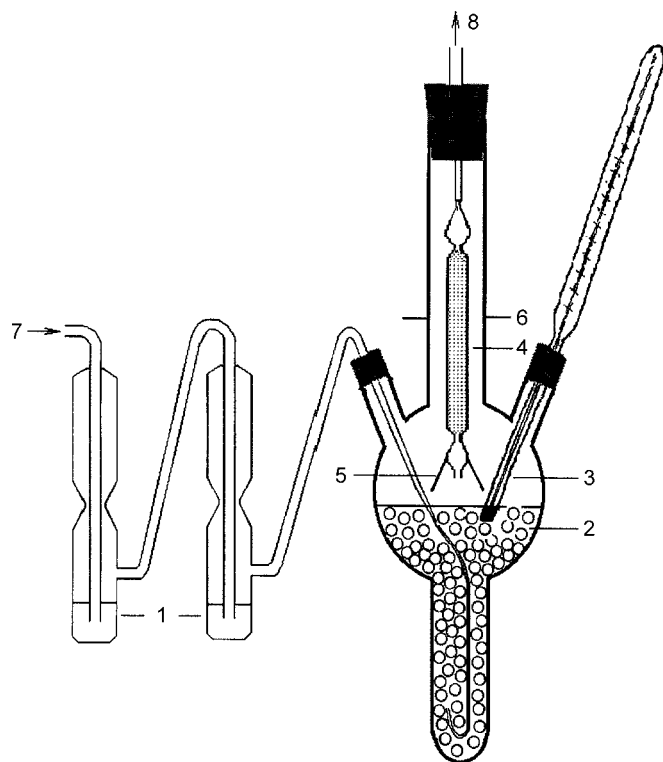

Fig. 4. Device for measurement of saturation water vapour pressure: 1, two bubblers for preliminary saturation; 2, water with glass beads; 3, thermometer; 4, weighed absorption vessel; 5, protective skirt; 6, water level in thermostat; 7, gas supply; 8, gas outlet.

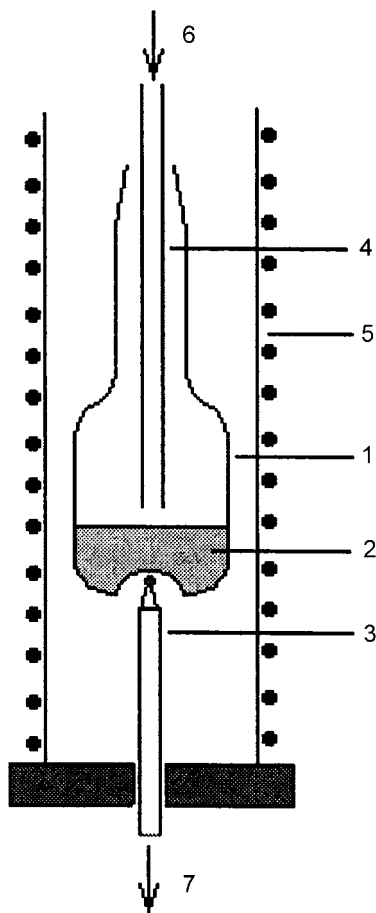

Fig. 5. Device for measurement of water vapour pressure (weight variant): 1, pyrex glass ampoule; 2, substance; 3, Pt–Pt/Rh thermocouple of derivatograph; 4, glass tube to deliver gas to the surface; 5, small non-inertial transparent furnace; 6, gas flow; 7, to the balance of derivatograph.

(Fig. 5) and filled with fresh calcined CaCl_2 , after passing 1 l of argon. It was collected in a volumetric flask, filled with water and turned upside-down. This water was preliminarily saturated with argon; the correction was made for the saturated water vapour pressure. In a typical experiment the value of the water vapour pressure was obtained, using the ideal gas law equation, to be equal to 19.2 hPa in comparison with the exact value 19.1 hPa at 289.9 K.

Fig. 5 illustrates the device used for these measurements. The temperature of the transparent furnace (5) was set with the electrical power system, including a voltage stabilizer, an autotransformer and an ammeter. The furnace was almost non-inertial, so that change of the electric current gave a new constant temperature in few minutes. Thus, we succeeded in a rapid increase and lowering temperature over and over again, and measuring the water vapour pressure in its dynamics.

The Pt–Pt/Rh thermocouple of the derivatograph was calibrated in the same furnace by using the precise thermometer, melting temperature of ice and boiling temperatures of pure organic liquids. The resulting uncertainty of the temperature measurements was obtained to be ± 0.8 K.

The specific surface area for the system $\text{CuCl}_2\text{--CuCl}_2\cdot 2\text{H}_2\text{O}$ samples was measured by the method of low temperature adsorp-

tion of argon. Microscope photographs for this system were obtained using Axio Imager.A1, Carl Zeiss, and powder X-ray diffraction (XRD) patterns were recorded on a diffractometer DRON-3 with Ni-filtered $\text{Cu K}\alpha$ radiation.

3. Results and discussion

Water vapour pressure for the system $\text{CaCl}_2\text{--CaCl}_2\cdot\text{H}_2\text{O}$ was measured using the gas transpiration method. The results obtained at 354.30 K are shown in Fig. 6 as a function of the gas velocity. It is well seen that no substantial velocity dependence is observed, indicating the equilibrium achievement.

At the same time there are two distinct horizontal lines for different states of the system. The upper line cannot correspond to the higher known hydrate ($\text{CaCl}_2\cdot 2\text{H}_2\text{O}$), because the equilibrium pressure for the dihydrate is about 33 hPa at this temperature. What are these states then? Our experiment does not specify their nature. One can only conclude that the difference in thermodynamic stability of these states is rather small, $\Delta_r G^\circ$ of the transition is at the level of about 1.6 kJ mol^{-1} . This effect may be quite explained in terms of physical differences between the participating phases, for instance, if there are two different crystal modifications, or if one of the phases is either bulk or super disperse.

We use the term “super disperse” because only the particle size at the rate of about few nanometres may appreciably change the Gibbs’s energy of the phase ($\Delta_r G$), as it is shown in Fig. 7 for the water droplets. These results were calculated using the Kelvin equation [4]

$$\ln P_r = \ln P_0 + 2\gamma Vr^{-1}(RT)^{-1}, \quad (3)$$

$$\Delta_r G = 2\gamma Vr^{-1}, \quad (4)$$

where P_r is the saturation vapour pressure of the water droplets with the radii r , P_0 is that for the bulk phase, γ is the excess surface energy of water, V is its molar volume, R is the universal gas constant and T is the temperature. It is as usually assumed, as the first approximation, that the values of γ and V are independent of the dispersity of the substance.

Does the thermodynamic theory give any chance to distinguish the two above-mentioned variants of explanation of the

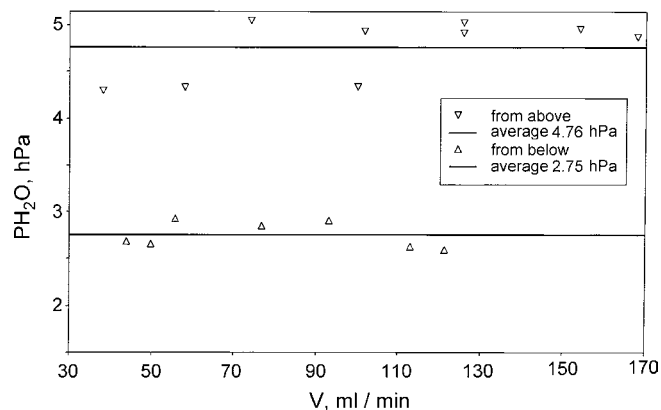

Fig. 6. Water vapour pressure for the system $\text{CaCl}_2\text{--CaCl}_2\cdot\text{H}_2\text{O}$ at 354.30 K.

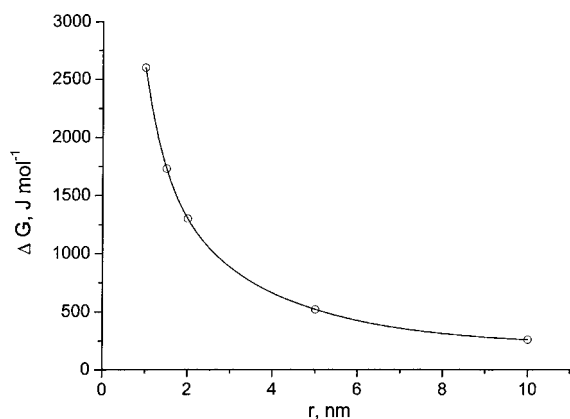
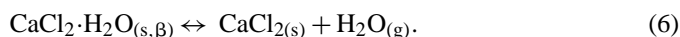
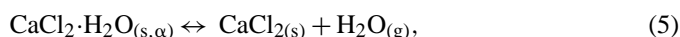

Fig. 7. Change of the Gibbs's energy with the radii of water droplets.

observed phenomenon (Fig. 6)? In the following we shall try to prove that it does.

Let us briefly review possible behaviour of a three-phase and two-component system, undergoing in a rather narrow interval of temperature two different transformations with closely related, but not exactly equal values of $\Delta_r H^\circ$ and $\Delta_r S^\circ$. The reactions (5) and (6) for the two different forms of calcium chloride monohydrate (α and β) give a proper example of such a system:



As it is well known, the temperature dependence of the corresponding equilibrium constants $K_P = P_w$,

where P_w is the equilibrium water vapour pressure for the reaction either (5) or (6), will be, in the coordinates $\ln P - T^{-1}$, two crossing straight lines as is shown in Fig. 8a. At the unique temperature of transition T_{tr} the system will be four-phase and non-variant, and at temperatures higher or lower only one form (α or β) will be stable, while the other – thermodynamically unstable. It does not mean that a phase cannot be obtained experimentally at temperatures where it is unstable, but it does mean that at this temperature it will be metastable, i.e. may exist temporarily, for more or less time without any transformation. We repeat here this well-known truth for it is very important for our further discussion.

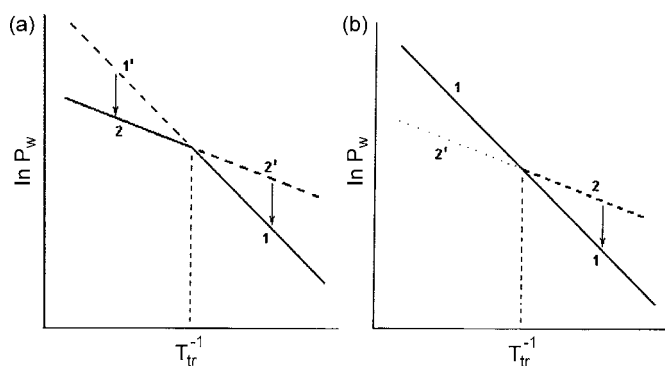
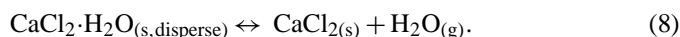
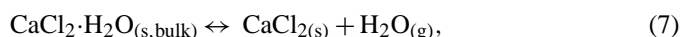

Fig. 8. Different forms of dependence of $\ln P_w$ versus reciprocal temperature: (a) usual form for two crystal modifications of the hydrate and (b) unusual form for the super disperse phase of the hydrate.

In Fig. 8a, lines (1) and (2) correspond to the stable forms of the monohydrate, and lines (1') and (2') – to the metastable forms, and at the temperature T_{tr} a change of the stable form may be observed. Therefore, the usual form of such a functional dependence is just shown in Fig. 8a – crossing firm lines. As it is noted above, the metastable equilibrium lines (1') and (2') may also be observed.

In Fig. 8b, an unusual form of such dependence is represented for the second above-mentioned case, when one of the phases (monohydrate) is either bulk or super disperse:



We shall assume for the beginning that the dispersity of the second phase (r in Eq. (4)) is constant and does not change with time. Use of Eq. (4) may raise well-founded questions in case of the quantitative calculations for solids, but we may undoubtedly use it for the deduction of qualitative relationships. For that we may assume the spherical shape of the concerned particles.

Turning back to Fig. 8b we may assert that, as it is shown below, in this case line (1) represents the stable equilibrium for the bulk phase (Eq. (7)), and line (2) – equilibrium for the unstable super disperse phase (Eq. (8)).

The following thermodynamic relations for the system concerned allow to make more clear some features of the phenomenon discussed. The super disperse phase of the hydrate, as is well known, has a higher Gibbs energy, so that the value of $\Delta_r G^\circ$ for the thermal dissociation of this phase is, as shown in Fig. 9, lower, than for the bulk stable phase. Therefore the water vapour pressure P_w , calculated from the thermodynamic equation

$$\Delta_r G^\circ = -RT \ln P_w, \quad (9)$$

should be higher for the disperse phase and increase as the reduction range rise.

Analogous diagram may be designed also for enthalpy, so that the enthalpy of the process (8) should be lower, than for the process (7). Thus, we obtain line (2) in Fig. 8b for the thermal decomposition of a super disperse phase. Therefore, the formation of a super disperse hydrate in the process of this

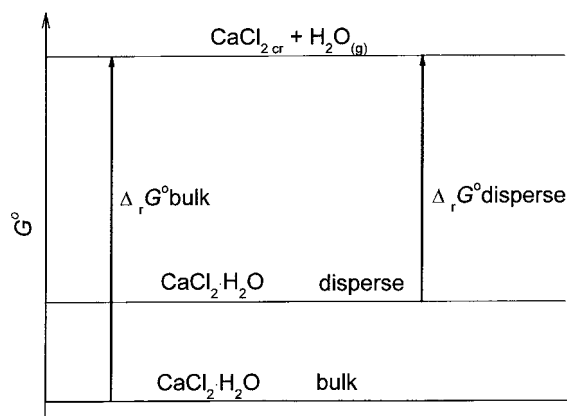

Fig. 9. Change of the Gibbs energy for the thermal dissociation of $\text{CaCl}_2 \cdot \text{H}_2\text{O}$.

type leads not only to the increase of the “equilibrium” water vapour pressure but also to underestimation of the enthalpy of this process.

It is very important to understand, that the upper line (2) in Fig. 8b has a double nature (the same is for line (2') in Fig. 8a) – on the one hand, it corresponds to the true equilibrium of the super disperse phase with water vapour, and the value of P_w in this case will be constant until the particle size is unchanged; on the other hand, the nano-size particles themselves are thermodynamically unstable and should sooner or later grow and turn into the bulk phase. From this point of view line (2), as well as line (2') in Fig. 8a, corresponds to the unstable equilibrium.

The most striking difference between these two figures lies in the character of lines (2) (Fig. 8a) and (2') (Fig. 8b), and also of the appropriate lines (1) and (1'). Prolongation of line (2) in Fig. 8b, that is line (2'), is obviously impossible, for in such systems the disperse phase should always be thermodynamically unstable. Hence, line (1) in Fig. 8b corresponds to the true equilibrium both before and after its intersection with line (2).

Returning to Fig. 6 we should mention again, that our experiments do not allow to distinguish these two variants – Fig. 8a and b. For that we should use the data received by Lannung [5], who has measured the equilibrium of calcium chloride monohydrate decomposition with a static method. Lannung [5] observed indeed two lines (1) and (2') (Fig. 8a), and drew a conclusion that two crystal modifications of the calcium chloride monohydrate were formed – α and β , as it is shown in Eqs. (5) and (6). The data of Lannung [5] are presented in Fig. 10 together with our data, received using the transpiration method.

In order to decide between the two cited variants, we should know the position of the line in Figs. 8 and 10 at temperatures higher than T_{tr} . There is an old source of such information – the data of Roozeboom [6], also given in Fig. 10. It is well seen that, in spite of low precision of these data [6], the plotted value is line (1) continuation. Therefore we should choose, following to Lannung [5], the variant shown in Fig. 8a, that is to acknowledge the formation of the two crystal modifications (α and β) of the calcium chloride monohydrate.

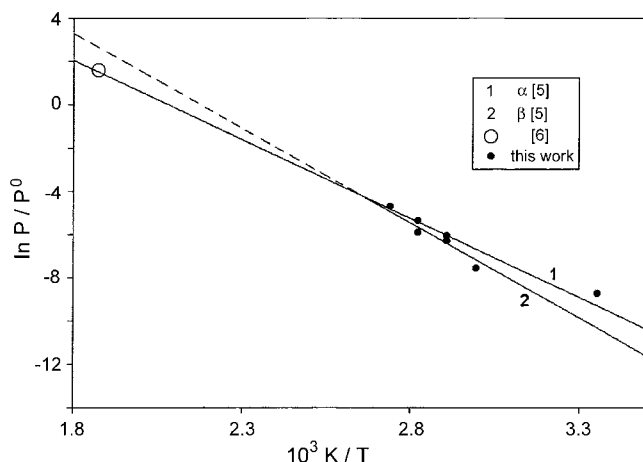

Fig. 10. Thermal decomposition of calcium chloride monohydrate.

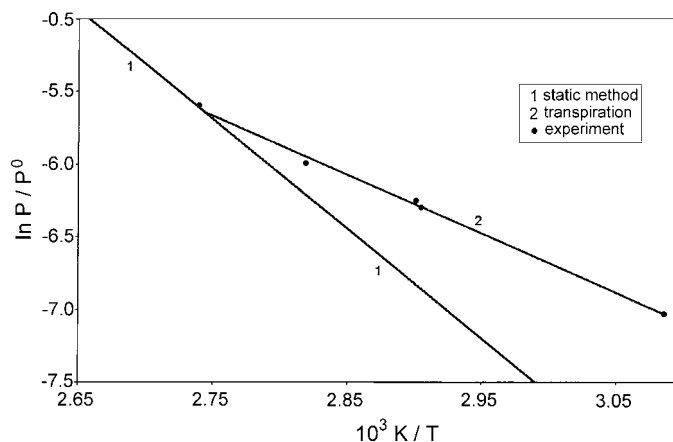

Fig. 11. Water vapour pressure for the system $\text{MnCl}_2\text{-MnCl}_2\cdot\text{H}_2\text{O}$.

Our experiments have shown that the data in Fig. 6 (and Fig. 3) were reproduced over and over again at repeated change of pressure of the incoming water vapour (measurements from below and from above). Consequently at 354.30 K (and also at 344.05 K) equilibrium was established sufficiently rapidly in both directions. At the highest temperature (364.85 K) we observe (Fig. 10) only one value because it is situated near the lines crossing, and the differences are apparently within the range of the data scattering. At 334.05 and 298.25 K, the rate of equilibration in one direction may be already so slow that we also observe only one value.

Water vapour pressure for the system $\text{MnCl}_2\text{-MnCl}_2\cdot\text{H}_2\text{O}$ was measured using both the static method with a glass membrane null-manometer and the dynamic gas transpiration method (Fig. 11). The data obtained with the static method give a very important thermodynamic information concerning the corresponding equilibrium and are worth of special discussion elsewhere. What is more important now, is the difference between the true equilibrium data (static method) and the data obtained with the gas transpiration method (Fig. 11). The latter received “from above” and “from below” are in a good agreement with one another. Thus, in Fig. 11 we observe two different equilibrium states – line (1) corresponds to the stable, true equilibrium, and line (2) – to the unstable one.

Now if we compare Fig. 11 for the system $\text{MnCl}_2\text{-MnCl}_2\cdot\text{H}_2\text{O}$ with Fig. 8, then it is well seen that it closely resembles Fig. 8b. Therefore, we may conclude that line (2) in Fig. 11 corresponds to the unstable equilibrium of the super disperse phase of the manganese chloride monohydrate with water vapour. The data received “from above” and “from below” are reproduced over and over again and are in good agreement with one another, and this indicates a rather high stability of the nano-size particles towards their growth in our transpiration experiments. As in case of the calcium chloride monohydrate, the equilibrium pressure for $\text{MnCl}_2\cdot 2\text{H}_2\text{O}$ is at these temperatures much more than for the monohydrate.

At present we have no information concerning the behaviour of line (2) in Fig. 11 near to the intersection with line (1) because of insufficient precision of the experimental data. But from general considerations we may suppose that this line should crook

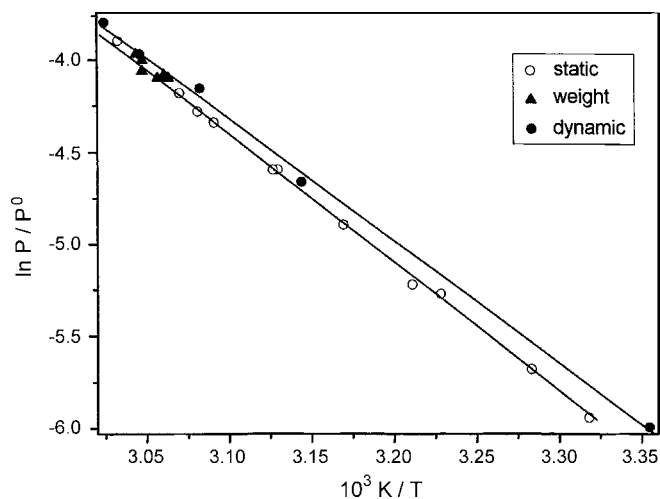

Fig. 12. Water vapour pressure for the system $\text{CuCl}_2\text{-CuCl}_2\cdot 2\text{H}_2\text{O}$.

upwards and approach to line (1) more gradually. When these lines merge, it should mean that in conditions of the given dynamic experiment nano-size particles of the hydrate have enough time to grow into the sufficiently coarse-grained, i.e. bulk phase.

Water vapour pressure for the system $\text{CuCl}_2\text{-CuCl}_2\cdot 2\text{H}_2\text{O}$ was measured using three methods – the static with a glass membrane null-manometer, the dynamic gas transpiration method and the weight modification of the static method. Special X-ray investigation confirmed the absence of any intermediate hydrate in this system – the received XRD patterns for CuCl_2 , $\text{CuCl}_2\cdot 2\text{H}_2\text{O}$ and their mixture (1:1), heated at 390 K for 6 h, are shown in Tables S1–S3 of the Supplementary Data.

The tensimetric results resemble those shown in Fig. 11, except for the difference between the lines is much smaller (Fig. 12). This may mean that the rate of the nano-scale particles growth is much higher, than in the previous case, so that the transpiration data are more close to the true equilibrium. The data received “from above” and “from below” are well reproduced. The main conclusion resulting from these experiments is that in case of copper (II) chloride we may also suppose the formation of the super disperse phase of the hydrate $\text{CuCl}_2\cdot 2\text{H}_2\text{O}$ in the process of water absorption by the anhydrous salt. But the most interesting results for this last system were obtained using the weight variant of the static method. Here, the above-mentioned higher rate of the particles growth enabled us to observe a real change of these phase thermodynamic properties during the experiment.

Approximately 0.4 g of ground $\text{CuCl}_2\cdot 2\text{H}_2\text{O}$ was placed into the ampoule (1) (Fig. 5), and the gas flow of dry argon passed over the surface of the substance at room temperature. The balance immediately showed loss of mass due to reaction (1). The rate of this process increased with rise of temperature, and soon the surface turned brown, indicating that the thermal dissociation spreads little-by-little deep into the substance. In that way, passing argon dry or saturated with water over the substance, we could achieve any desired fractional conversion in both directions. Moreover, at room temperature we could obtain a desired amount of the saturated solution of $\text{CuCl}_2\cdot 2\text{H}_2\text{O}$ in water.

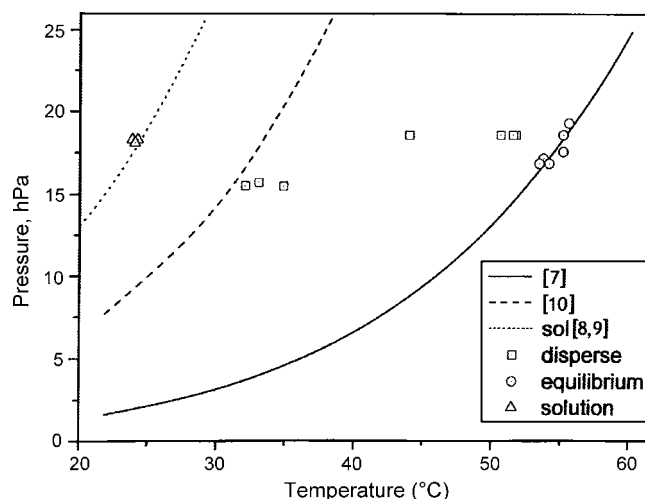

Fig. 13. Water vapour pressure for $\text{CuCl}_2\cdot 2\text{H}_2\text{O}$ and its saturated solution.

These experimental data are shown in Fig. 13. One can see that our data for reaction (1), designated as circles, are in good agreement with the equilibrium data of [7] (the right line in Fig. 13). They were received “from below” and never “from above” for the hydrate with a substantial degree of decomposition (30–60%) at the relatively high temperature (340–350 K), when the supposed super disperse phase should completely vanish. Obviously they correspond to the stable, bulk phase of $\text{CuCl}_2\cdot 2\text{H}_2\text{O}$. The data for the saturated solution of $\text{CuCl}_2\cdot 2\text{H}_2\text{O}$ in water are also quite close to the data of [8,9] (left line in Fig. 13). Therefore, reliability of the results obtained by the used experimental method is surely verified. However, the most surprising results are those designated as squares and placed in the middle of Fig. 13.

Three left values were received “from above” at a slow substance cooling with a subsequent stop of the temperature. We surmise that the multiple supersaturation caused the formation of the nucleation centers of the hydrate at the surface of CuCl_2 . We may imagine that the initial nanometric particles of the dihydrate with variable characteristics depending on their size are colloiddally dispersed on the surface of relatively large grains of anhydrous copper dichloride. In presence of water vapour, a sufficiently rapid growth or aggregation and formation of grosser particles occur in one way or another, so that after some time their properties practically do not depend on their size.

It was most difficult to obtain the values nearer to the right line (Fig. 13). They were caught after cooling the substance to the beginning of water sorption with a subsequent slow rise of the temperature until the quasi-equilibrium was reached.

Now the idea of a super disperse phase formation supposed on basis of the thermodynamic considerations and the above given experiments, receives new indirect evidence. We observe in Fig. 13 a real change of the thermodynamic properties of the unstable phase with time, i.e. rise of its temperature of decomposition, and the corresponding values in Fig. 13 tend to shift to the right. We may say that after a short time amounting to some minutes, the conversion to the more and more stable phase is observed, i.e. to the more and more coarse hydrate.

Many questions may arise concerning the phenomenon considered, and by no means all of them may be earnestly answered at present. One of the questions, that we are able to make clear now is the following. In view of the above shown results the data in Ref. [10] may relate to the unstable equilibrium of the reaction concerned, including the formation of the super disperse phase of the dihydrate $\text{CuCl}_2 \cdot 2\text{H}_2\text{O}$. Is it possible to obtain non-equilibrium data skilfully using the most precise and rigorous static method? We do not know all the experimental details of the work [10], but we can suppose a situation, that may lead to such results.

Let us assume that a sample of pure hydrate $\text{CuCl}_2 \cdot 2\text{H}_2\text{O}$ is taken for the investigation. Then the amount of the received anhydrous salt in conditions of the static method might be negligible. Therefore the process of evolution of the system towards the stable equilibrium “from above” will be accordingly very slow, as the rate of the nucleation and growth process for the hydrate should be proportional to the surface area of the anhydrous salt. So in this case it is quite possible to obtain values of the water vapour pressure relating to the unstable equilibrium. In our experiments there was always a sufficient amount of both products.

A simple rule may be formulated from the foregoing for studying a process of thermal dehydration, and obviously other processes of decomposition, using the static method. In contrast to vaporisation, no pure samples might be used; they should be necessarily a close mixture of the substance studied and the solid product of its decomposition in approximately equal quantities. This simple rule may help one to avoid different experimental complications and obtain more reliable thermodynamic information.

Inaccuracy of the derived reaction thermodynamics and of the standard thermodynamic constants of the hydrate, arising from the influence of this phenomenon, may be illustrated with the data for the hydrate $\text{CuCl}_2 \cdot 2\text{H}_2\text{O}$, since the authors of different reference books [11,12] proceed in this case from not the same experimental data. The most convincing are the values of its standard entropy S° (298.15), equal to 167 [11] and 190.63 $\text{J mol}^{-1} \text{K}^{-1}$ [12], the difference being much more than any expected experimental error. Therefore, reinvestigation is in some cases necessary to achieve more precise and more reliable thermodynamic data for the hydrates taking into account the above stated considerations.

It is necessary to emphasize the practical significance of the discussed phenomenon, regardless of its theoretical details. It may undoubtedly influence the results of experimental study of such reactions using the dynamic methods like the transpiration one, but it should also be taken into account using all the other methods including, as we have seen, the most accurate, static one.

Can we obtain any direct evidence of the super disperse phase formation? For that we have tried to use, but without any success, two methods – specific area measurements of different samples of the system CuCl_2 – $\text{CuCl}_2 \cdot 2\text{H}_2\text{O}$ (Table S4) and microscopical analysis of this system (Fig. S1a and Fig. S1b of the Supplementary Data). None of the samples studied gave any evidence of the super disperse phase formation; and it is no won-

der, for its lifetime is short. Moreover, such a phase should quickly decompose under the conditions of such measurements (dry helium + argon). Microscope photographs for this system (Fig. S1a and Fig. S1b) cannot give any information about nano-scale particles for their invisibility in an optical microscope. However, as may be seen, these photographs do not contradict to the theory of nucleation and growth – the brown surface of the large anhydrous CuCl_2 particles (55–100 μm) is dotted with small blue crystals of $\text{CuCl}_2 \cdot 2\text{H}_2\text{O}$ (0.9–2.5 μm). It is necessary to mention that electron microscope is also useless at studying these objects for they should immediately decompose in vacuum.

4. Conclusion

Rather surprising findings have been received as a result of the thermodynamic study of the dehydration and rehydration processes of calcium, manganese and copper dichlorides, resembling each other within certain limits. In case of CaCl_2 these results are accounted by the formation of the two different crystal modifications of the monohydrate, but for the rest a hypothesis is advanced of a hydrate super disperse phase formation.

It is necessary to emphasize that we have received no convincing and actual proof of the super disperse phase formation, and it is not clear whether it could be received for the substances discussed at all. However, this idea enables us to suppose a unified and sequential interpretation of the main results obtained. It seems to be a boundary area between the chemical kinetics and thermodynamics, their dominant role being defined by the chemical rate and the time of thermodynamic measurements.

It is shown that such a super disperse phase formation is able to change appreciably the experimental results. More precise and reliable data for the thermal dehydration processes may be obtained taking into consideration this phenomenon.

Acknowledgements

The authors express thanks to N.V. Akulich, Regional Scientific Centre of Kuleshov State University, Mogilev, for help in the microscopic measurements, and to Yu.G. Zonov, Institute of General and Inorganic Chemistry, Belarus Academy of Science, for help in the X-ray investigations.

Appendix A. Supplementary data

Supplementary data associated with this article can be found, in the online version, at [doi:10.1016/j.tca.2007.11.005](https://doi.org/10.1016/j.tca.2007.11.005).

References

- [1] A.K. Galwey, *Thermochim. Acta* 355 (2000) 181–238.
- [2] O.G. Polyachenok, L.D. Polyachenok, E.N. Dudkina, Method for gas dehydration, Belarus Patent No. 7795 2002-09-10.
- [3] O.G. Polyachenok, L.D. Polyachenok, E.N. Dudkina, Method for controlled gas dehydration, Belarus Patent No. 8998 2004-05-19.
- [4] A.W. Adamson, *Physical Chemistry of Surfaces*, Wiley, New York, 1976.

- [5] A. Lannung, *Z. anorg. allg. Chem.* 228 (1936) 1–18.
- [6] B. Roozeboom, *Z. Phys. Chem.* 4 (1889) 31–53.
- [7] R. Perret, *Bull. Soc. Chim. France* 2 (1966) 755–758.
- [8] M. Diesnis, *Bull. Soc. Chim. France* 2 (5) (1935) 1901–1907.
- [9] M.H. Lescoeur, *Ann. Chim. Phys.* (7) 2 (1894) 78–117.
- [10] I.H. Derby, V. Yngve, *J. Am. Chem. Soc.* 38 (1916) 1439–1451.
- [11] D.D. Wagman, W.H. Evans, V.B. Parker, R.H. Schumm, I. Halow, S.M. Bailey, K.L. Churney, R.L. Nuttall, *J. Phys. Chem. Ref. Data* 11 (1982) 2–392.
- [12] V.P. Glushko (Ed.), *Thermal Constants of Substances, Reference Book in 10 Issues*, VINITI, Moscow, 1965–1982 (in Russian).